

# Study of $W\gamma$ events at the CMS experiment

Devdatta Majumder  
Kajari Mazumdar



*XIX DAE-BRNS High Energy Physics Symposium  
Jaipur, December, 2010*

# Outline

- Physics of  $W\gamma$  events
- Event reconstruction in CMS
- Event selection
- Signal extraction  
(estimating purity of signal)
- $W\gamma$  cross-section measurement
- Summary

# Physics of multibosons

## The Standard Model of particle physics

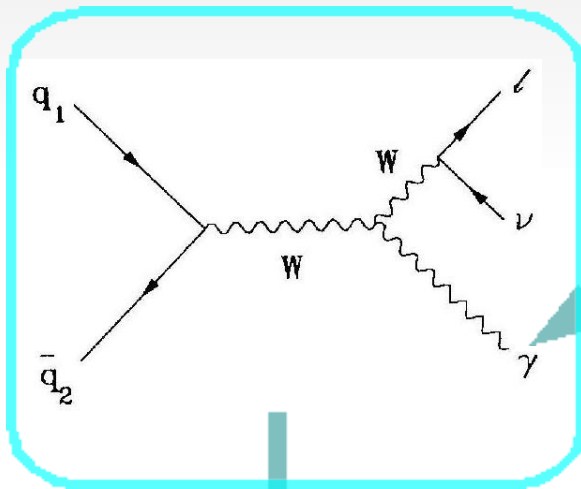
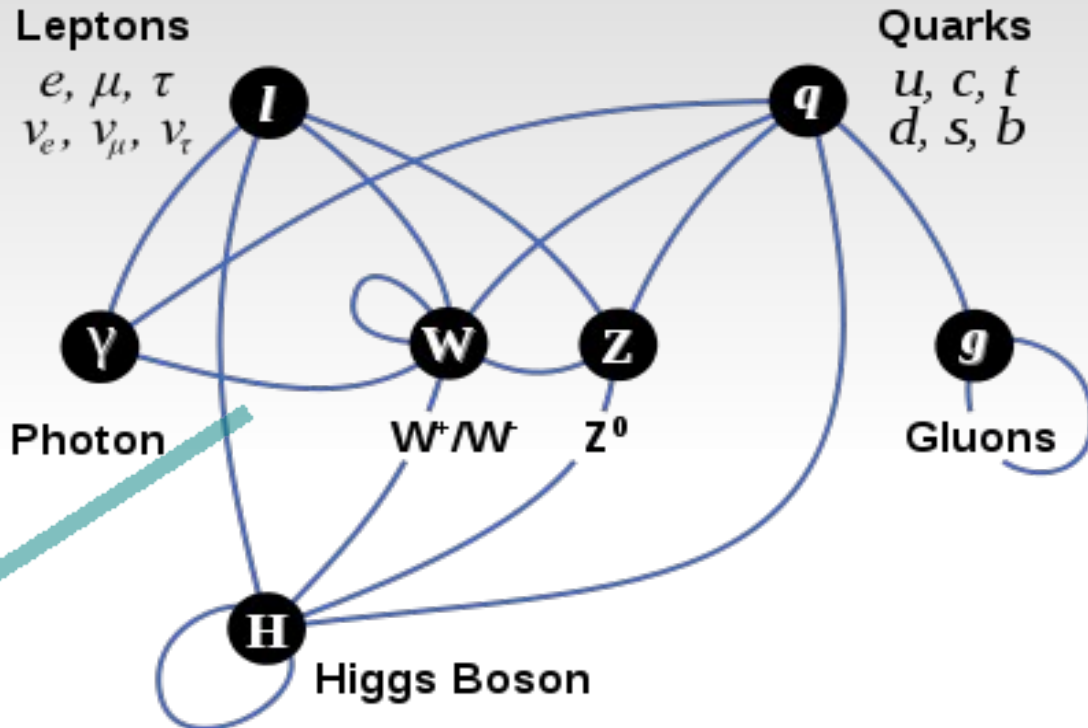

**Aims:**

- **Measure cross-section**  
 $d\sigma(pp \rightarrow \mu\nu\gamma) / dp_T^\gamma$ 
➔ **Measure strength of WW $\gamma$  coupling**

# Our physics goals

- Most general Lorentz, electromagnetic gauge and CP-invariant Lagrangian for the  $WW\gamma$  vertex has two parameters  $\kappa$  and  $\lambda$ .
- Physically  $\kappa$  and  $\lambda$  related to the electric quadrupole and magnetic dipole moments of the W boson:
  - $$\mu_{\mathbf{W}} = \frac{e}{2M_{\mathbf{W}}}(\mathbf{1} + \kappa + \lambda) \quad \mathbf{Q}_{\mathbf{W}} = -\frac{e}{2M_{\mathbf{W}}^2}(\kappa - \lambda)$$
- In SM at tree level:  $\kappa=1$  and  $\lambda=0$
- Deviation of  $\kappa$  and  $\lambda$  from SM values will be manifested as enhancement of  $W\gamma$  cross-section especially at high photon transverse momentum.

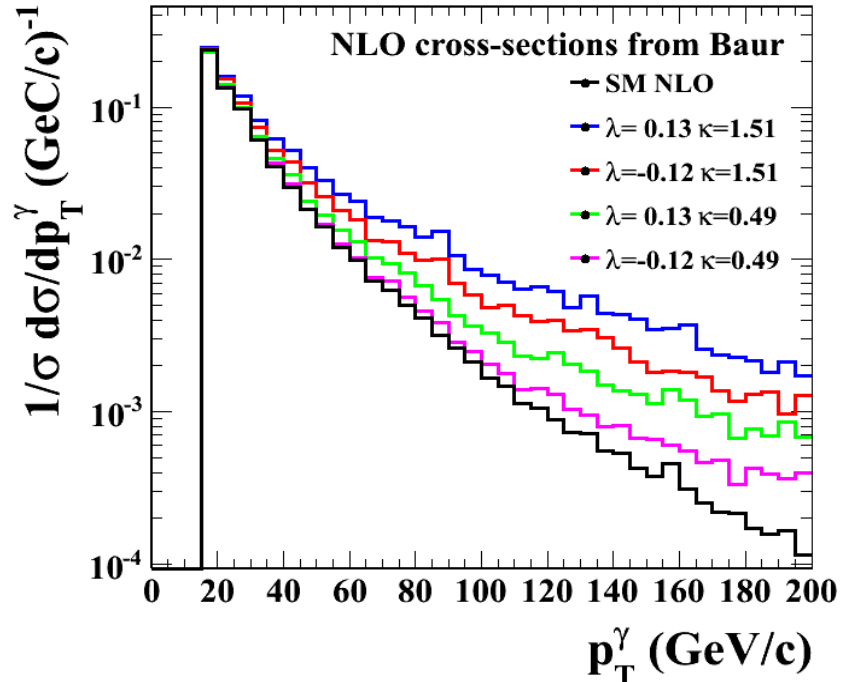
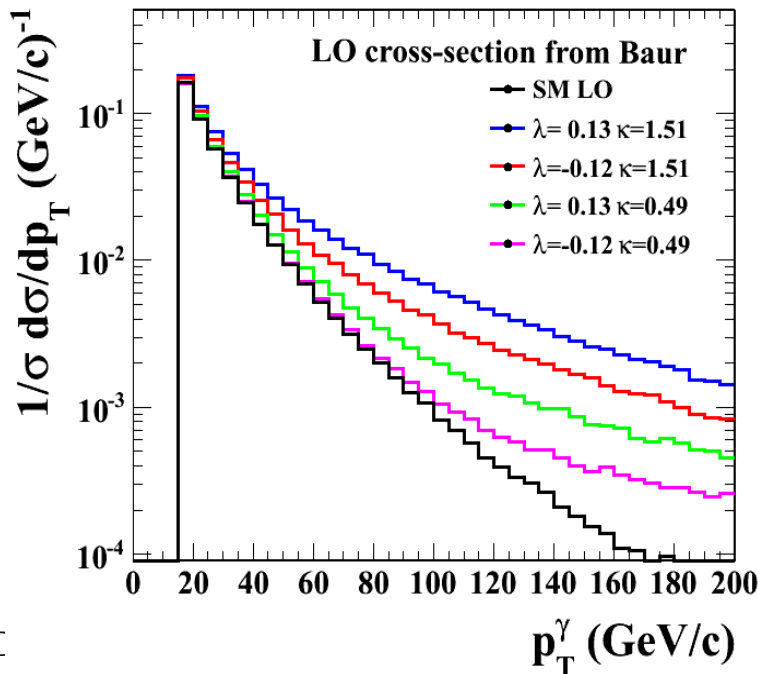

# Signal ( $W\gamma \rightarrow \mu\nu\gamma$ ) process

## Born level graphs

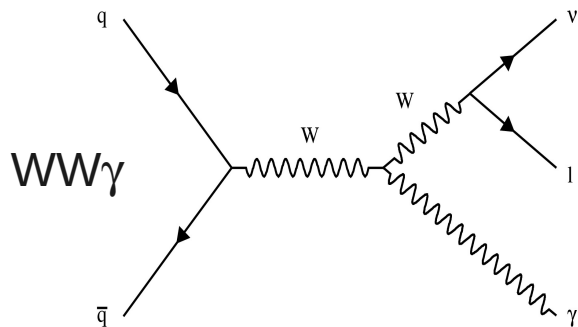
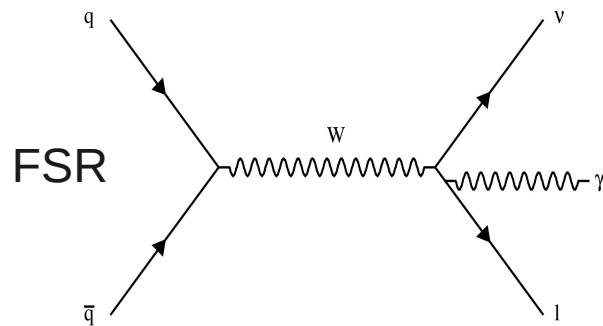
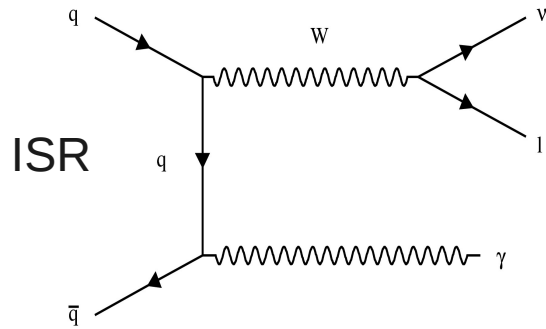

- Signal process is  $pp \rightarrow W\gamma + X$ 
  - $X$  = mostly hadrons from underlying events and sometimes hard jets.
  - LO cross-section = 23.2 pb from Pythia with  $p_T^\gamma > 10 \text{ GeV}/c$ .
    - $p_T$  is momentum transverse to the beam direction.
  - NLO cross-section = 41.76 pb from Baur WGAMMA NLO.
- To reconstruct  $W\gamma$  events:
  - Reconstruct the lepton (muon).
  - Reconstruct Missing transverse energy from neutrino (MET).
  - Reconstruct the photon.

# Background processes

<p>Real lepton Real photon</p> <p><b>Signal: <math>W\gamma \rightarrow \mu\nu\gamma</math></b></p> <p>Irreducible background:  <math>Z\gamma \rightarrow \mu\mu\gamma</math>  <i>(determined from Monte Carlo)</i></p>	<p><b>Fake: Type I</b></p> <p>Real lepton Fake photon:  <i>(largest background contribution)</i></p> <p>W+jets (<math>\sigma_{LO} = 24.17 \text{ nb}</math> <math>\sigma_{NLO} = 31.3 \text{ nb}</math>)</p> <p>Z+jets</p> <p><math>t\bar{t}</math>+jets</p> <p>Dibosons (WW, WZ, ZZ)</p>
<p><b>Fake: Type II</b></p> <p>Fake lepton Real photon</p> <p>QCD</p>	<p><b>Fake: Type III</b></p> <p>Fake lepton Fake photon</p> <p>QCD</p>

# Event reconstruction in CMS

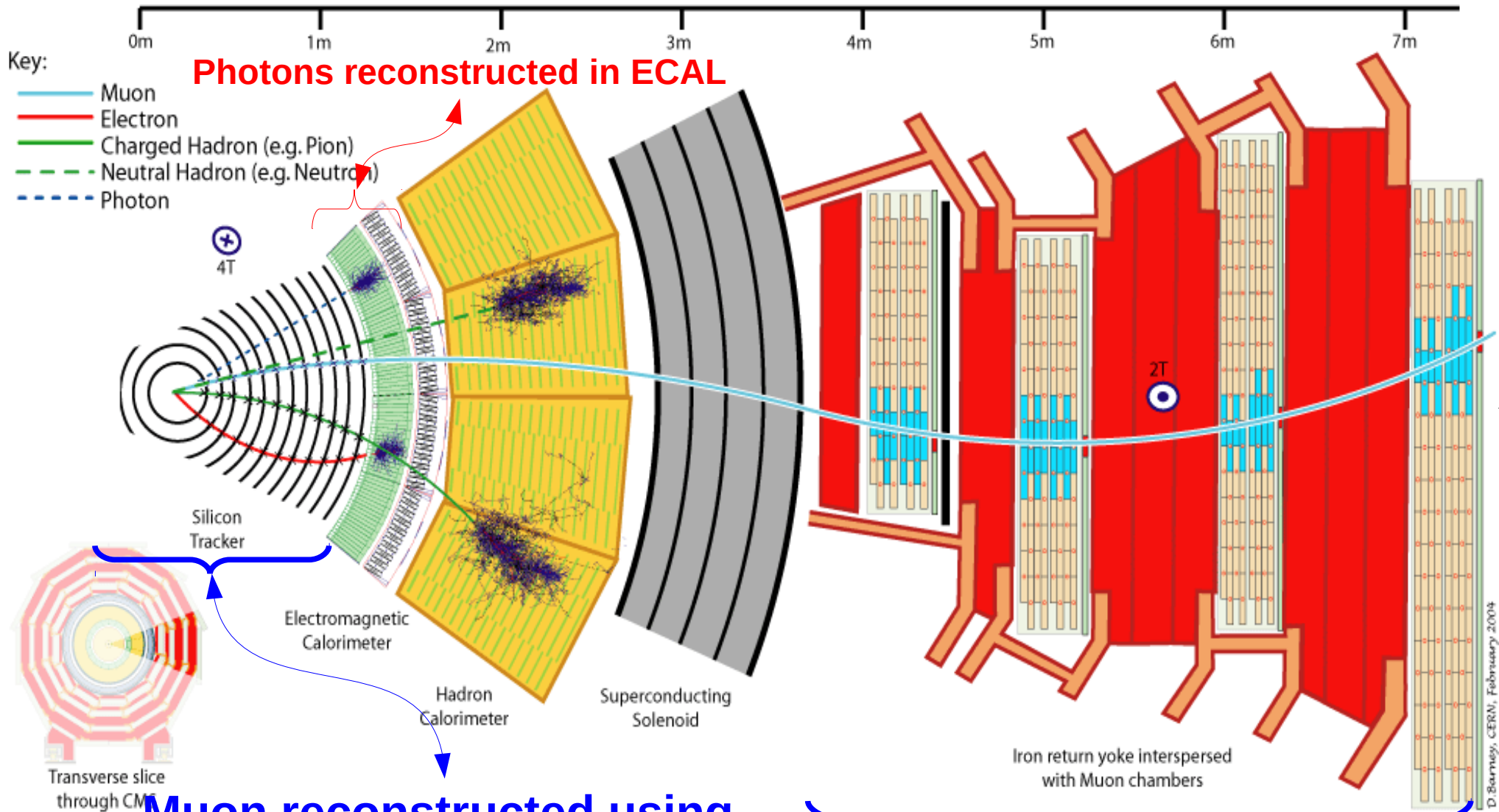

**Muon reconstructed using silicon tracker and muon chambers**

# Selection of $W\gamma$ events

- W boson selection
- Photon selection

# Event selection criteria

## Event trigger

- Single muon trigger
- $p_t^\mu > 9 \text{ GeV}/c$ ,  $11 \text{ GeV}/c$  or  $15 \text{ GeV}/c$  depending on run range.

## W selection

- W transverse mass  $M_T^W > 50 \text{ GeV}/c^2$

## Photon selection

- $p_T^\gamma > 10 \text{ GeV}/c$  and  $|\eta^\gamma| < 2.5$
- 95% of the photons' energies should be deposited in the ECAL.
- Photons should be isolated.
- Photons and muons should be well separated:  $\Delta R_{\mu\gamma} > 0.7$ .

## Muon selection

- $p_T^\mu > 20 \text{ GeV}/c$  and  $|\eta^\mu| < 2.1$
- No high  $p_T$  2<sup>nd</sup> muon:  
*removes Drell-Yan background.*
- Good quality reconstruction in both tracker and muon chamber.
- Muons should be isolated.

$\eta = -\log(\tan\theta/2)$ ,  $\theta$  is azimuthal angle.

$$\Delta R_{\mu\gamma} = \sqrt{(\eta_\gamma - \eta_\mu)^2 + (\phi_\gamma - \phi_\mu)^2}$$

# W event selection

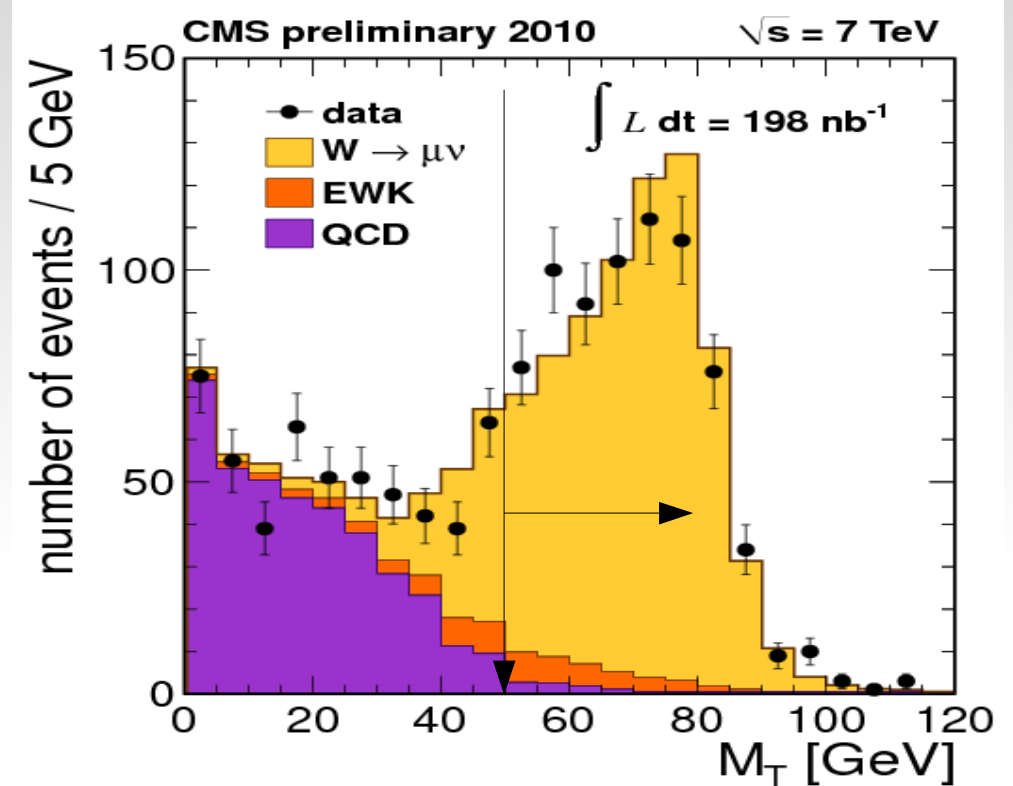
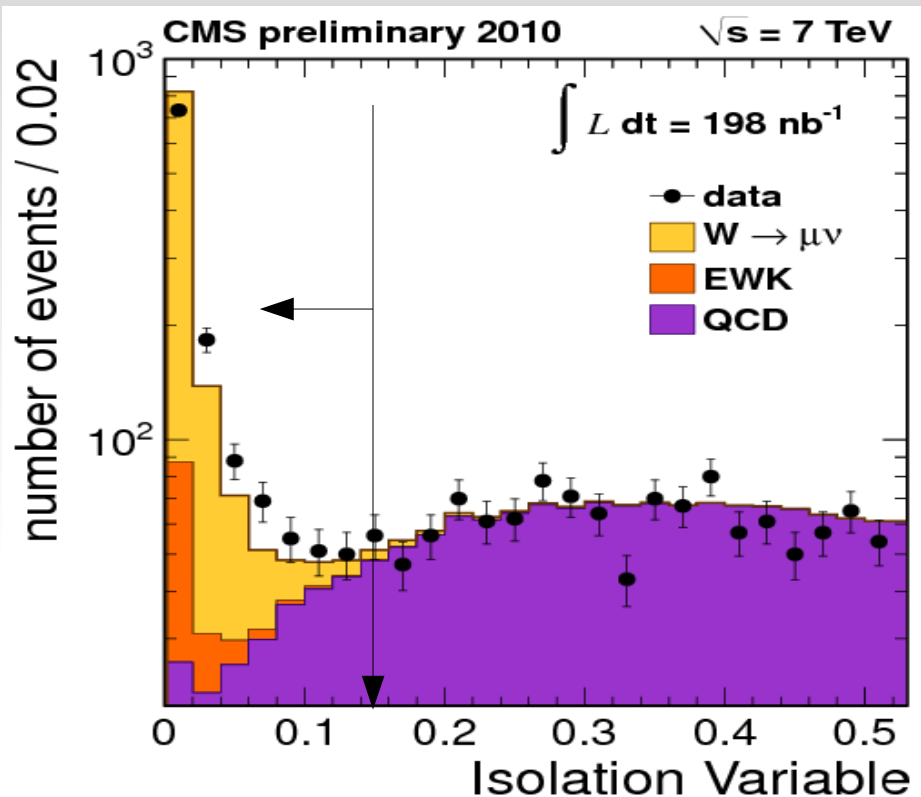

- Relative isolation used for W boson selection in a cone  $\Delta R < 0.3$  :

$$I_{\text{combined}}^{\text{rel}} = \left( \sum p_T(\text{tracks}) + E_T(\text{em}) + E_T(\text{had}) \right) / p_T^\mu$$

- The  $M_T^W$  cut removes almost all backgrounds from QCD.

# A $W\gamma$ event

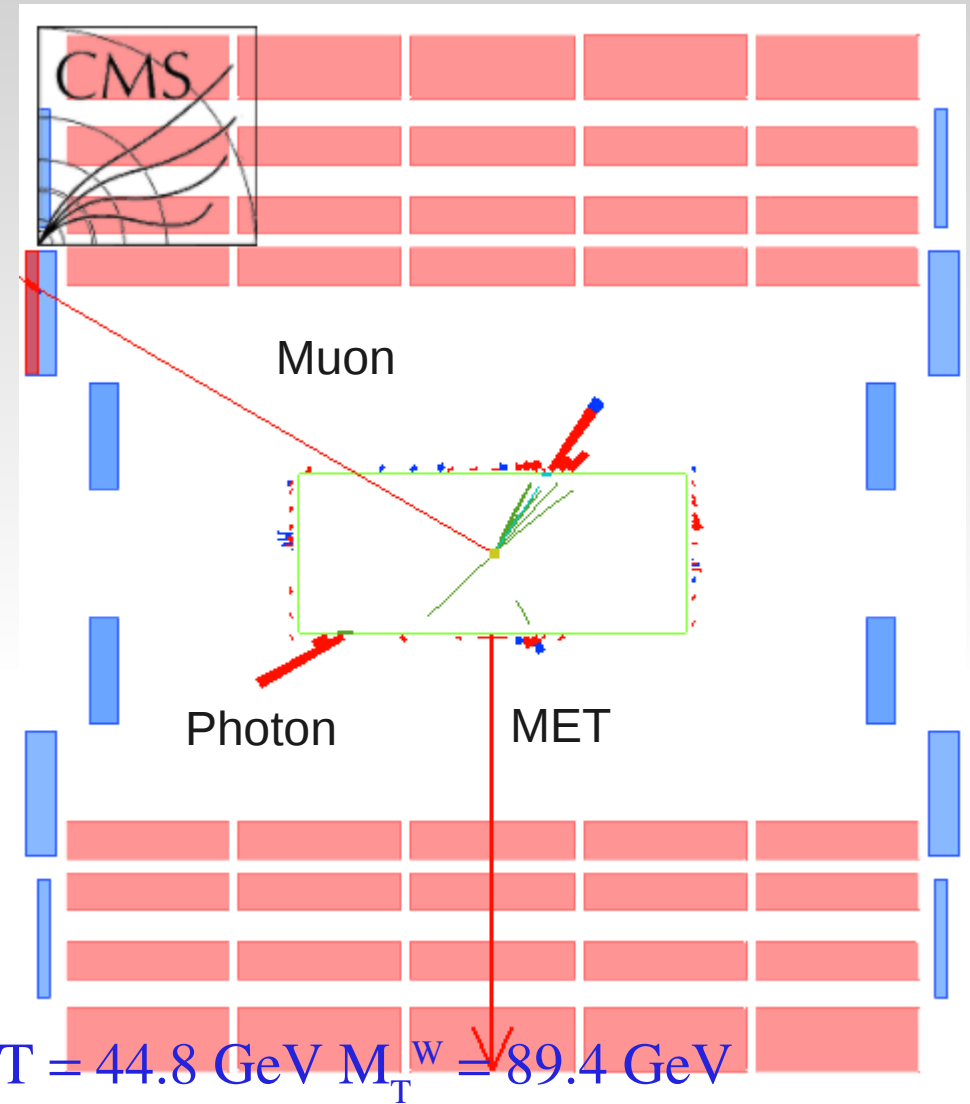
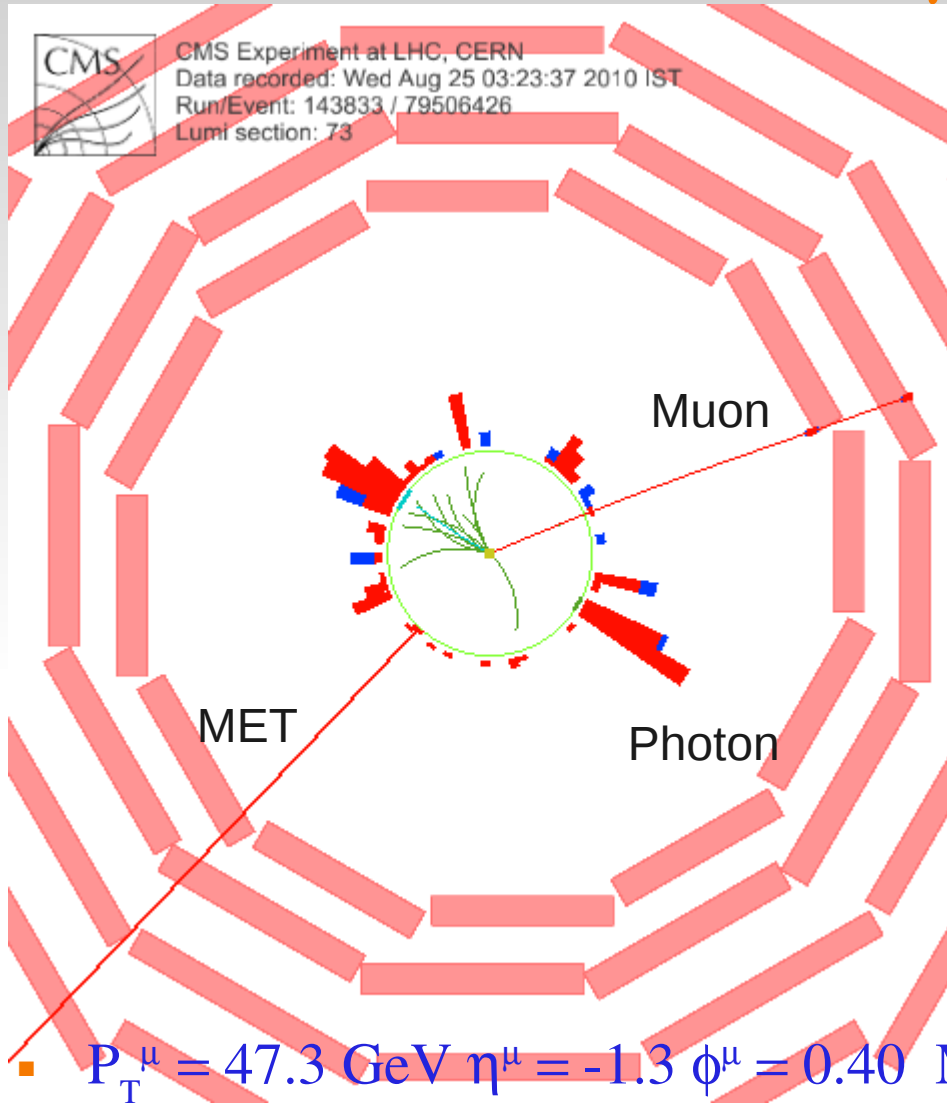

- $P_T^\mu = 47.3 \text{ GeV}$   $\eta^\mu = -1.3$   $\phi^\mu = 0.40$   $\text{MET} = 44.8 \text{ GeV}$   $M_T^W = 89.4 \text{ GeV}$
- $P_T^\gamma = 11.3 \text{ GeV}$   $\eta^\gamma = -1.4$   $\phi^\gamma = -0.53$   $\gamma \text{ trk iso} = -0.13$   $\gamma \text{ ecal iso} = -0.23$   $\gamma \text{ hcal iso} = -0.19$   $\Delta R(\mu, \gamma) = 0.94$

# $W\gamma$ candidate that failed $\Delta R(\mu,\gamma)$ - FSR photon

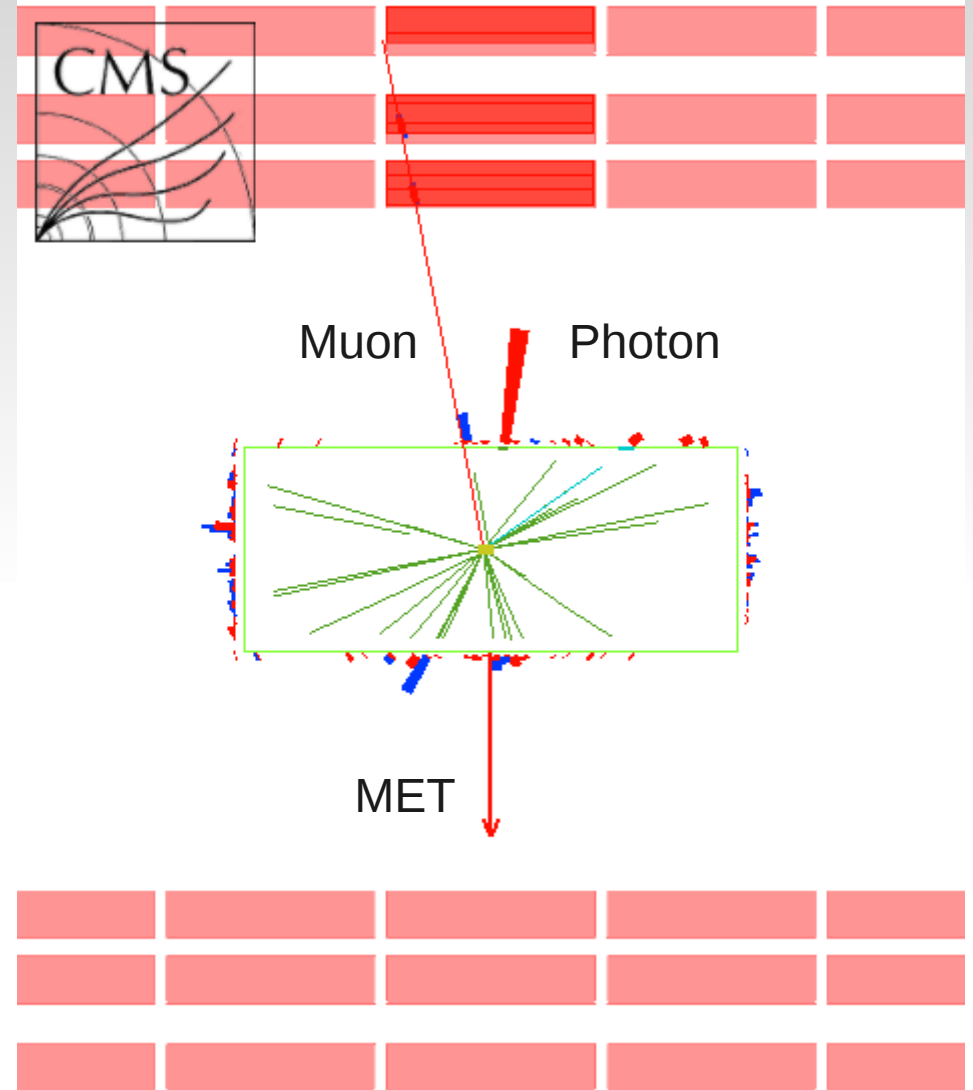
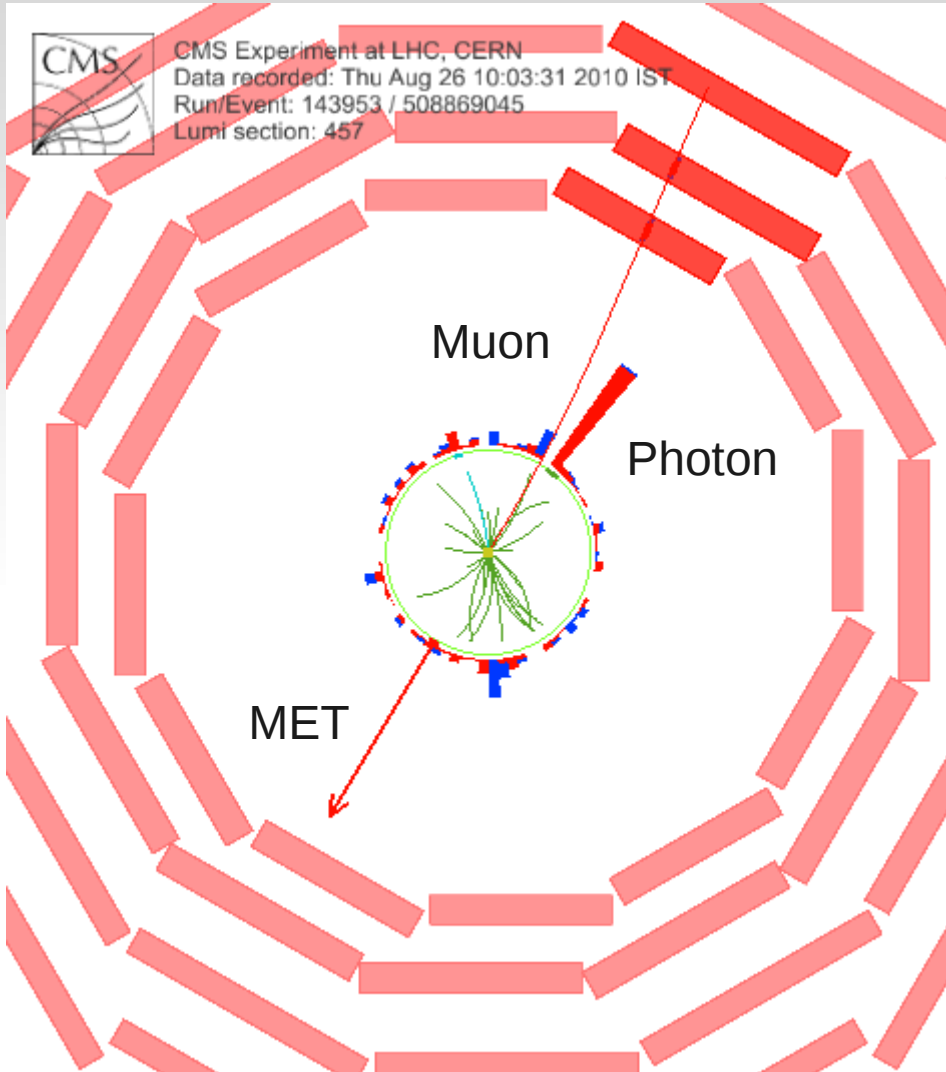

- $P_T^\mu = 25.0 \text{ GeV}$   $\eta^\mu = -0.20$   $\phi^\mu = 1.0$
- $P_T^\gamma = 19.16 \text{ GeV}$   $\eta^\gamma = 0.19$   $\phi^\gamma = 0.89$   $\Delta R(\mu,\gamma) = 0.40$

# Event that failed $W\gamma$ selection - non-isolated photon

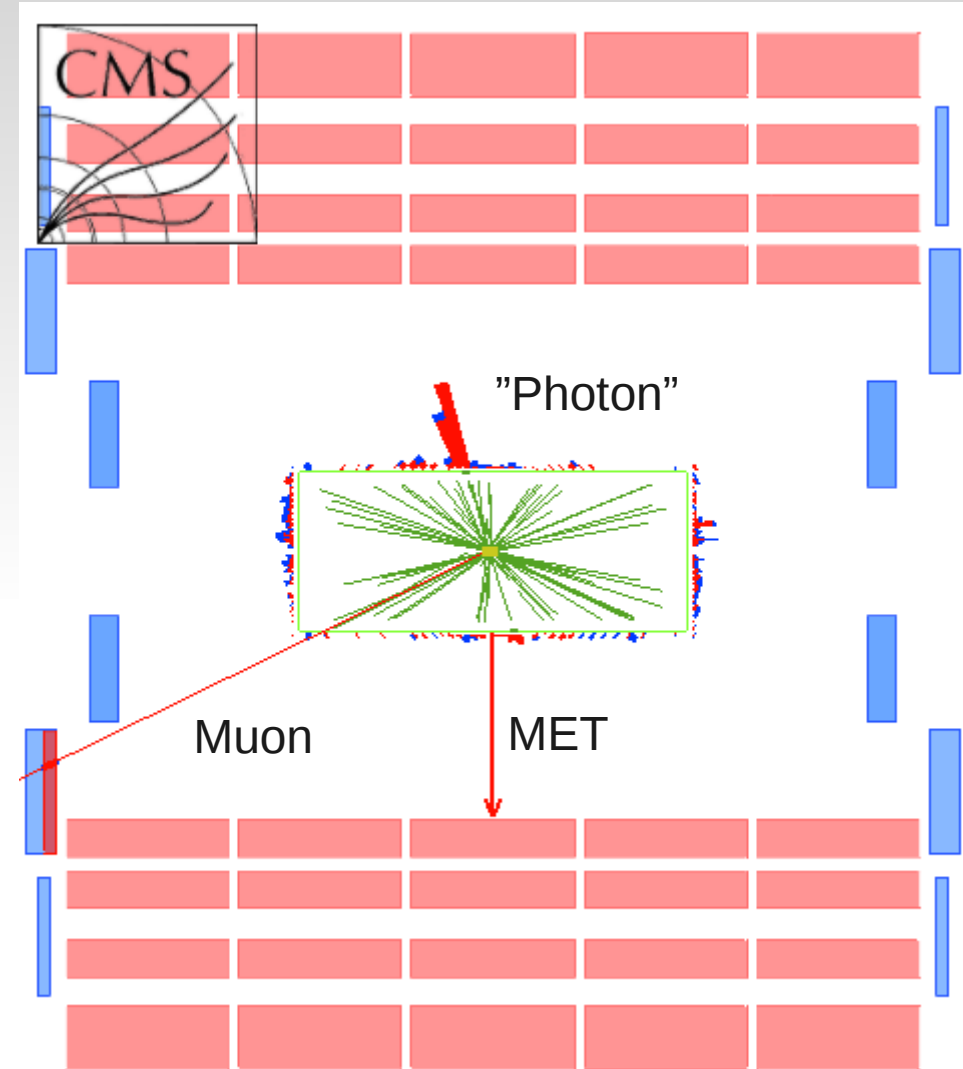
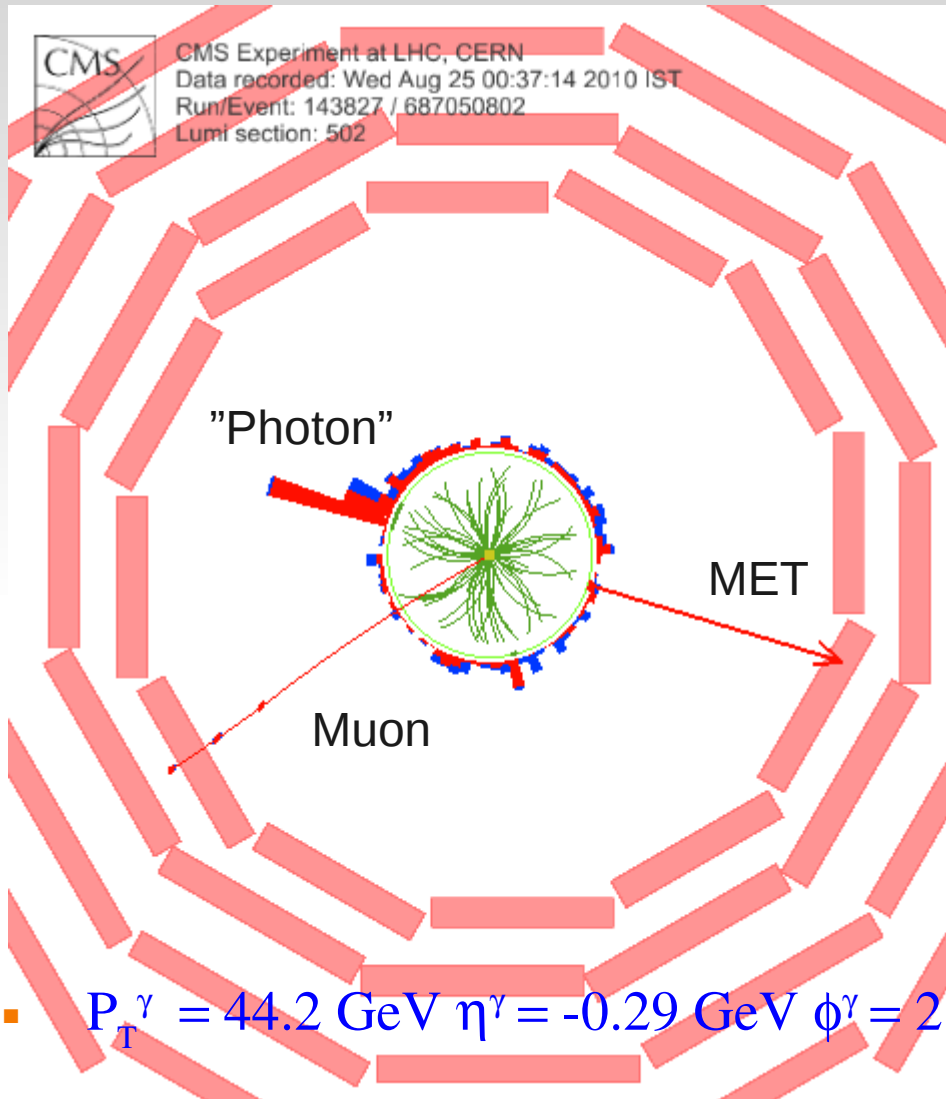

- $P_T^\gamma = 44.2 \text{ GeV}$   $\eta^\gamma = -0.29$   $\text{GeV}$   $\phi^\gamma = 2.8$
- $H/E = 0.05$   $\gamma \text{ trk iso} = -0.04$   $\gamma \text{ ecal iso} = 0.03$   $\gamma \text{ hcal iso} = 0.11$
- $\Delta R(\mu, \gamma) = 1.4$

# Estimating backgrounds

- Jets fake photons (W+jets or Z+jets mostly)
  - Neutral mesons in jets
  - Low fake rate
  - High cross-section
- Estimate fake content using data:
  1. Choose variable with distinct shape for signal and background.
  2. Make templates for signal (real prompt photons)
  3. Make templates for fakes (from independent data sample)
  4. Fit simultaneously to selected candidate events
- Used for the Measurement of the Isolated Prompt Photon Production Cross Section at CMS (arXiv:1012.0799)
  - Results will be shown from this paper.

# Background estimation using templates - I

- We make templates using a variable called  $\sigma_{i\eta i\eta}$  (sigma i-eta i-eta)

$$\sigma_{i\eta i\eta}^2 = \frac{\sum_i^{5 \times 5} w_i (i\eta_i - i\eta_{seed})^2}{\sum_i^{5 \times 5} w_i}, \quad w_i = \max(0, 4.7 + \ln \frac{E_i}{E_{5 \times 5}})$$

- 2<sup>nd</sup> moment of the shower distribution along  $\eta$  direction in ECAL.

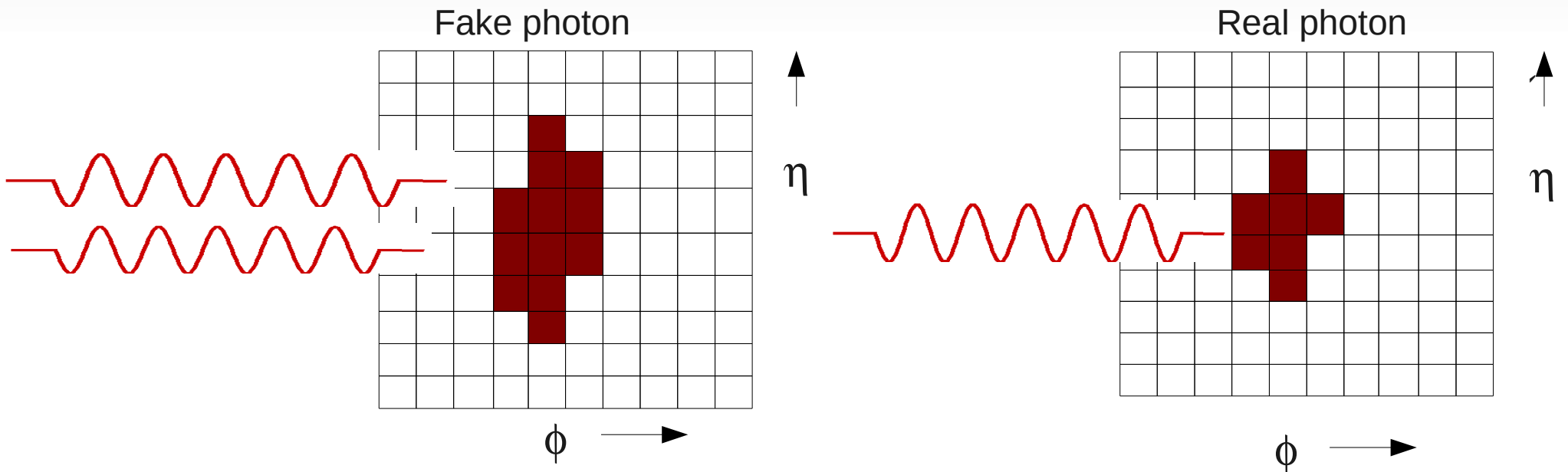

# Background estimation using templates - II

- Make distribution of  $\sigma_{i\eta i\eta}$  for signal and background in different ranges of  $p_T^\gamma$ .
- Signal shapes are from MC.
- Background shapes are from data
- Fit the  $\sigma_{i\eta i\eta}$  distribution from data with the signal and background templates using a binned maximum likelihood.

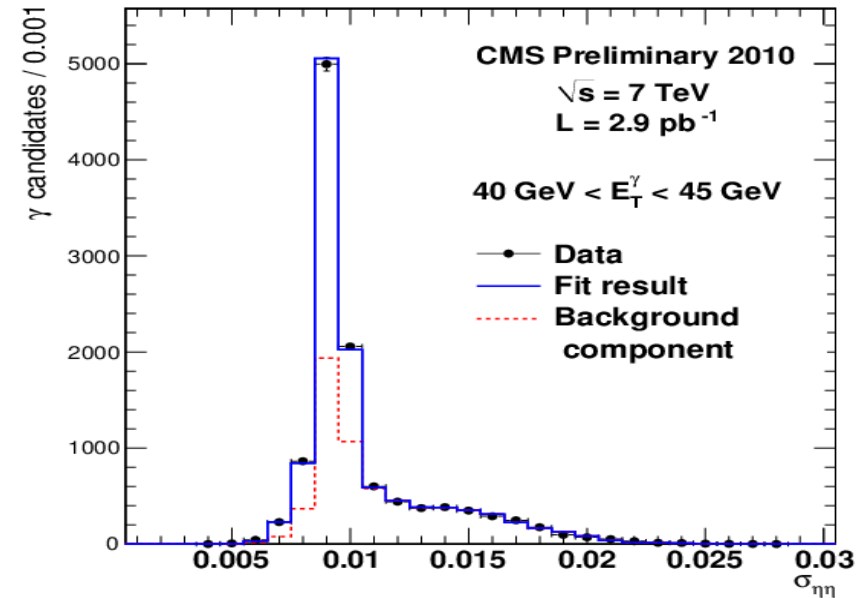
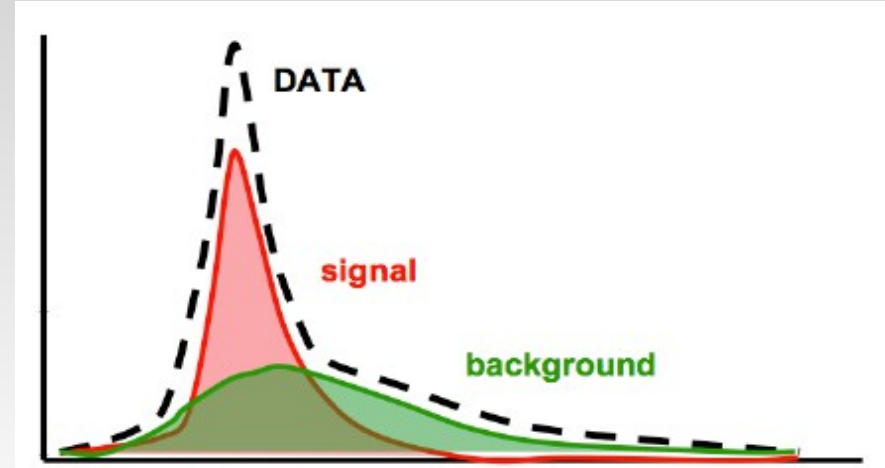

$$\mathcal{L} = -\ln L = (N_S + N_B) - \sum_{i=1}^n (N_S S_i + N_B B_i)$$

- This gives the fraction of signal and background in data.

# $W\gamma$ cross-section measurement

$$\sigma \times \mathcal{BR}(W \rightarrow \mu\nu) = \frac{N_{events} - N_{bkg}}{\epsilon_{reco} \epsilon_{trig} \epsilon_{\mu ID} \epsilon_{\gamma ID} \mathcal{AL}}$$

Number of events selected

Number background events estimated

- Reconstruction efficiency
- Trigger efficiency
- Muon selection efficiency
- Photon selection efficiency

Detector acceptance:  
Calculated using MC samples.

Integrated luminosity

# Estimating efficiencies - Tag and Probe

- We aim to estimate efficiency using *data-driven methods*.

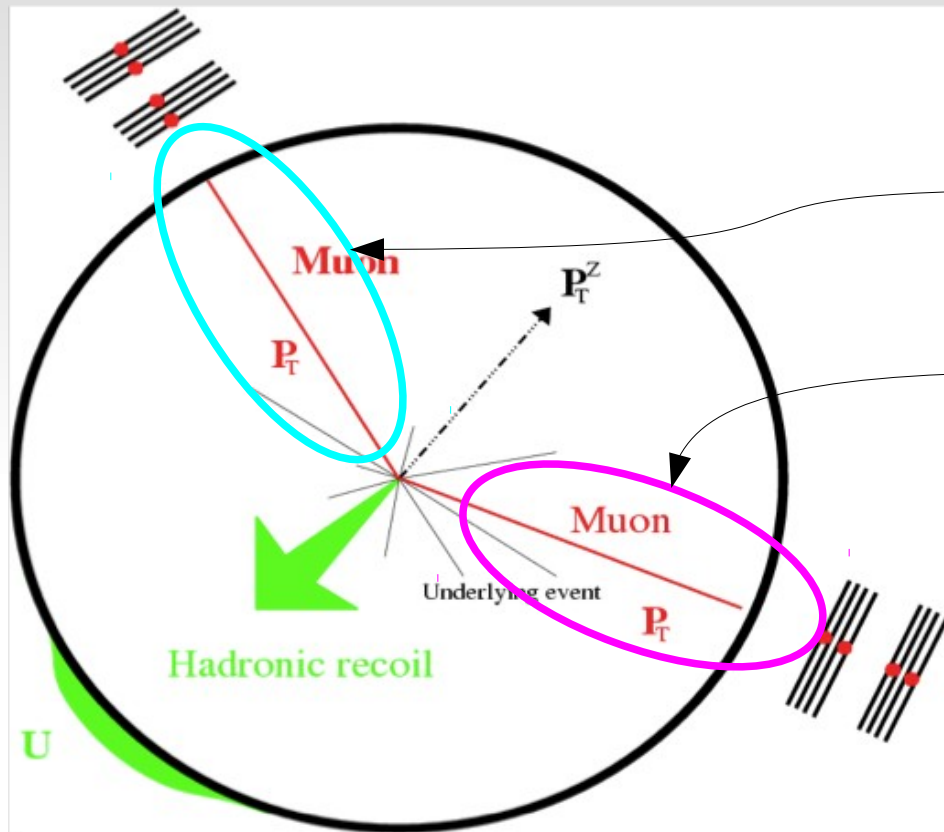

For photon efficiency use  $Z \rightarrow ee$  where electrons emulate photons.

Select dimuon events.

Tag muon:  
Should pass strict quality cuts.

Probe muon:  
Required to pass looser cuts.

Make tag-probe pairs: Inv. mass of tag-probe must be close to Z mass.

Count number of probes that pass a particular selection criteria.

$$\text{Selection efficiency} = \frac{\text{probes passing a selection}}{\text{all tag - probe pairs}}$$

# Systematic uncertainties

Sources of uncertainty
Muon ID+iso
Photon ID+iso
MET energy scale and resolution
Photon energy scale
Photon energy resolution
Background estimation
MC generator/k-factor
Acceptance uncertainty
Luminosity

- Largest uncertainty is due to the template shapes in the background estimation method. ( $\sim 15\%$ ).
- Luminosity uncertainty given as an external input ( $\sim 11\%$ ).
- Other uncertainties are much less than the statistical uncertainty on the cross-section measurement.
- All components for the cross-section measurement are ready and are being finalized.

# Summary

- We look forward to the first measurement of the  $W\gamma$  cross-section and  $WW\gamma$  coupling measurement at an entirely new energy regime, that of the LHC.
- The interesting part of the analysis starts at photon  $p_T$  above 50 GeV/c when we become sensitive to the measurement of the  $WW\gamma$  coupling and we can probe the anomalous gauge coupling of the  $W$  and the photon.
- This is an ongoing work nearing completion. Many of the techniques for background determination and efficiency estimation are adopted from CMS analyses for  $W$  and  $Z$  boson and prompt photon production processes.

# Backups

# Making signal templates

- Signal template generated from direct photons in photon+jet MC.
- Correction factor applied from data:
- Select Z->ee samples in data and make templates.
- Measure  $\langle \sigma_{\eta\eta} \rangle$  difference between data and MC distributions for Zee candidates and correct the MC photon template by this difference.
- $\langle \sigma_{\eta\eta}^{\text{Data}} \rangle - \langle \sigma_{\eta\eta}^{\text{MC}} \rangle = (8 \pm 3) \times 10^{-5}$  in barrel and  $(3 \pm 1.2) \times 10^{-4}$  in the endcap.
- Background templates are made from data.

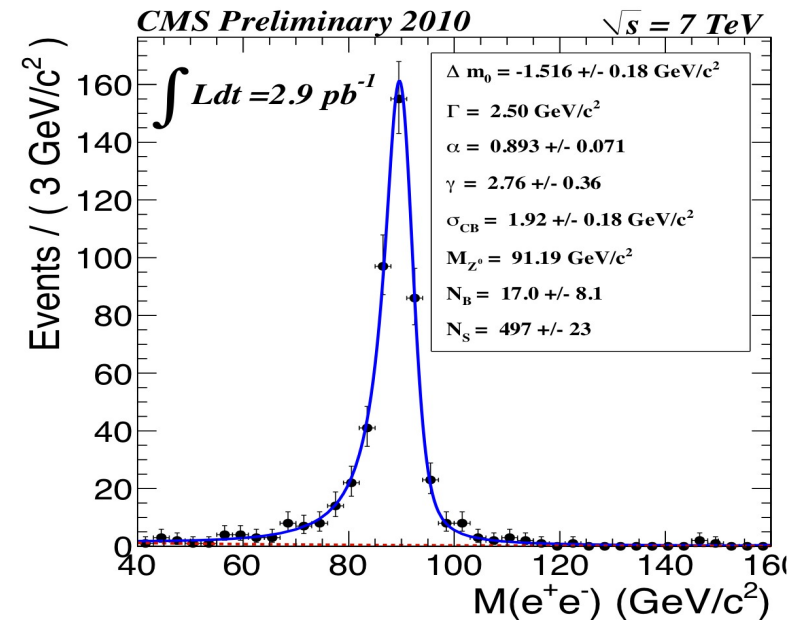
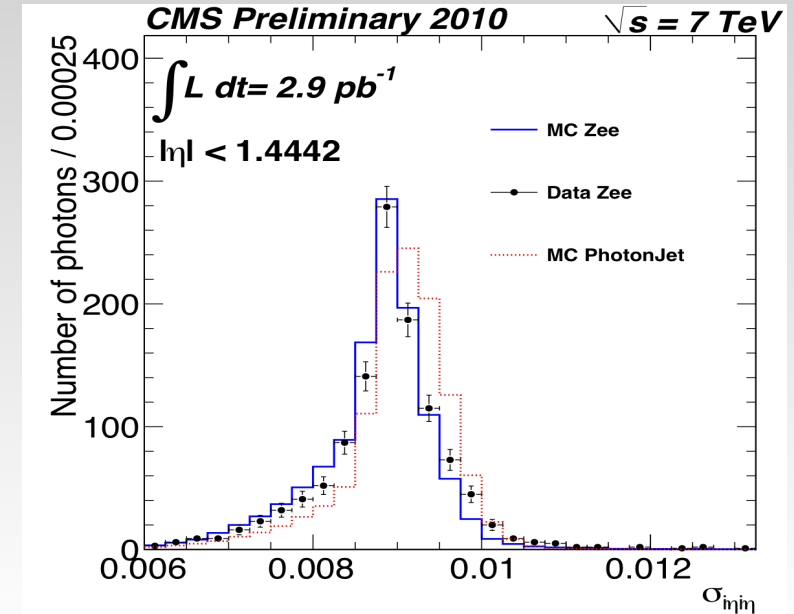

# Signal extraction

- The signal and background templates are fit to data using a two-component maximum likelihood fit.
- The difference in signal yield when the signal shape is shifted within the data-MC correction uncertainty is assigned as a systematic uncertainty.
- Further, the difference between the background template shape in the sideband and the signal region also contributes to the systematic uncertainty of the fit.
- Total systematic uncertainty due to the signal extraction procedure  $\sim 15\%$ .

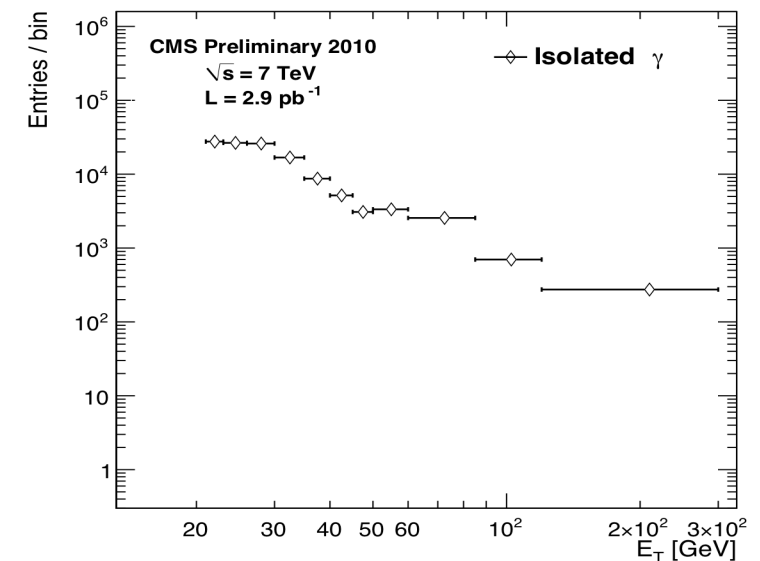
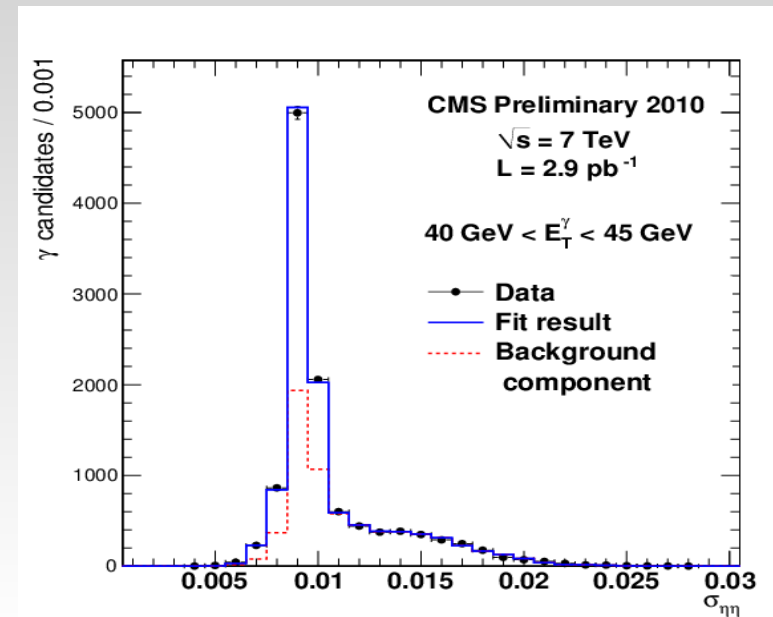

# Making background templates

- Background templates produced from track isolation sideband:  $2 \text{ GeV} < \text{track iso} < 5 \text{ GeV}$  in jet enriched data.
- The sideband in MC matches well with the background in the signal region.

